

▲ REMOVE JUMPER WHEN USED.

(A) WIRE IS NOT USED WHEN EXTERNAL INTERLOCK SWITCH OR STOP BUTTON IS USED.

(B) OBSTRUCTION SENSING DEVICES MAY BE N.O. TYPE (STANDARD AIR SWITCH, ELECTRIC EDGE, ETC.) OR N.C. "FAIL-SAFE" TYPE (PHOTOCELL, ETC.)..

(C) MOVE RED WIRE FROM # 7 TO # 5 FOR MOMENTARY PRESSURE TO CLOSE.

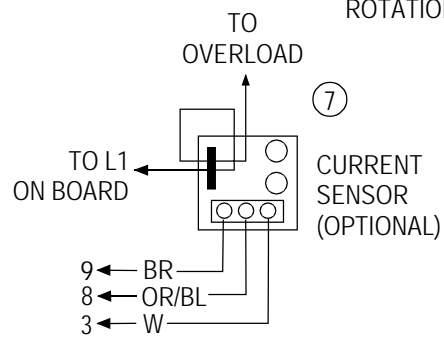

LOOP DETECTOR

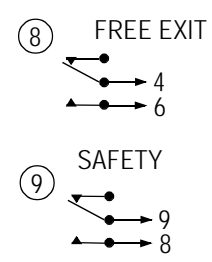

PowerMaster	
MODEL MH/MJ/MT PRB MOTOR CONTROL	
DATE: 5-22-01	REV. 6
BY: F.S.	R.P.L.
SPECIAL: PSC MOTOR	
WIRING DIAGRAM LD-345	
© Copyright PowerMaster 1997 No portion of this diagram may be reproduced without the expressed written permission of the manufacturer.	